



V-Guide

CAM Roller Technology

Roller Bearings & Linear Guideways



Configure Online at
pbclinear.com

1-800-962-8979

V-Guide Wheels, Rails & Bushings

REDI-RAIL

| V Guide Wheel | | Size | | Weight | | Per Wheel Radial Load | | Axial Load | |
|---------------|-----|------|-------|--------|------|-----------------------|-------|------------|-----|
| | | mm | in. | G | oz. | N | lb. | N | lb. |
| Size 1 | VW1 | 20 | 3/4 | 12 | 0.42 | 1,260 | 283 | 297 | 67 |
| Size 2 | VW2 | 30 | 1 1/4 | 40 | 1.41 | 2,730 | 614 | 632 | 142 |
| Size 3 | VW3 | 45 | 1 3/4 | 136 | 4.79 | 6,166 | 1,386 | 1,448 | 326 |
| Size 4 | VW4 | 60 | 2 1/4 | 285 | 10 | 9,991 | 2,246 | 2,313 | 520 |



COMMERCIAL RAIL

FEATURES & BENEFITS

V-Guide systems are an industry standard for linear motion, and offer features that make them an ideal solution for a wide range of motion control applications.

- Radial loads up to 9.9 N (2,246 lb.) per wheel
- Axial loads up to 2.3 N (520 lb.) per wheel
- Precision dual row angular contact design
- Operating temperature range from -20°C to 80°C (-4°F to 176°F)
- Concentric or eccentric wheel bushings in inch and metric sizing

HARDENED CROWN ROLLER

FOLLOWER ROLLERS

V-Guide Wheels

V-Guide wheels are precision ground, dual row angular contact ball bearings with hardened outer way surfaces that provide low friction guidance for linear motion applications. They can be used with internal or external 90-degree ways – or used with round shafts.

- Four sizes
- Permanently sealed and lubricated
- Precision dual row bearing construction
- Available in 52100 bearing steel or 420 stainless steel construction
- 304 stainless steel shields or nitrile rubber seals

V-Guide Rail

Rails are induction hardened, ground, and polished. The track body is left soft for easy drilling of mounting holes. Four sizes are designed to correspond with wheel sizes.

- Has shoulder for simple mounting and alignment
- Induction hardened way surface
- 1045 carbon steel or 400 series stainless steel
- Optional black oxide finish
- Rails are cut to length, MAX length up to 5,486.4 mm (216")

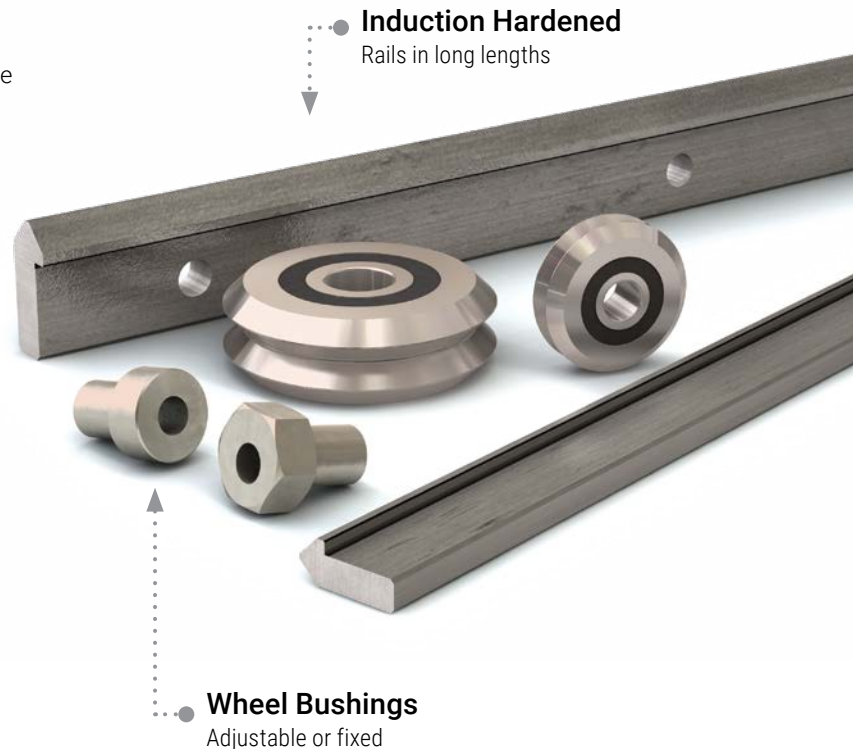

Wheel Bushings

- 303 stainless steel construction
- Inch or metric hardware
- Adjustable bushings allow adjustable fit and preload
- Fixed bushings are used in the primary radial load direction

HEVI-RAIL

Wheels, Rails & Bushings V-Guide

1:1 Scale

Size 1: VW1

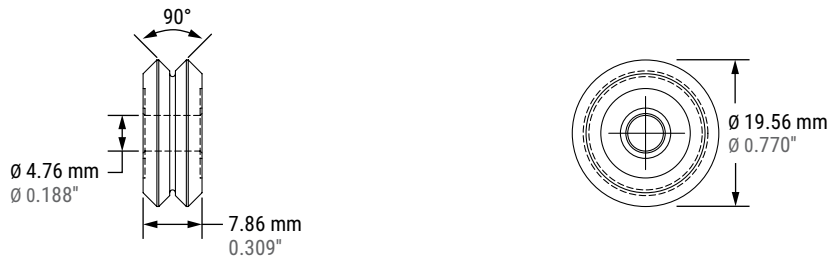

Size 2: VW2

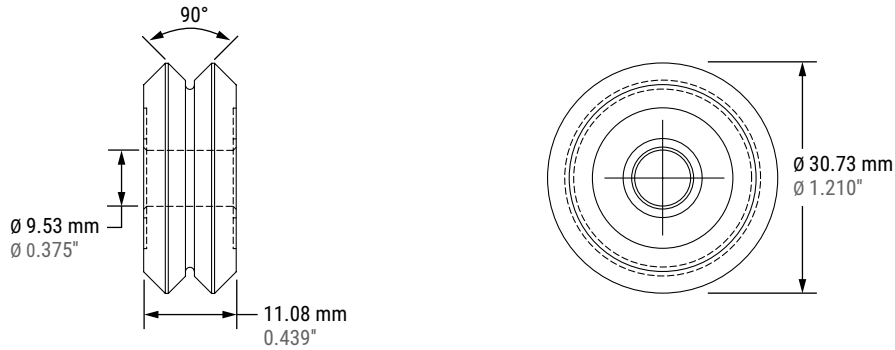

Size 3: VW3

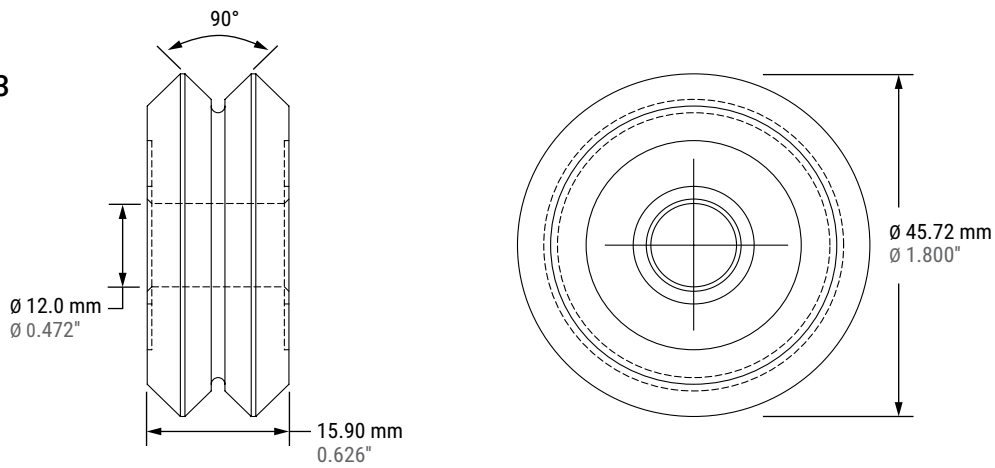

Size 4: VW4

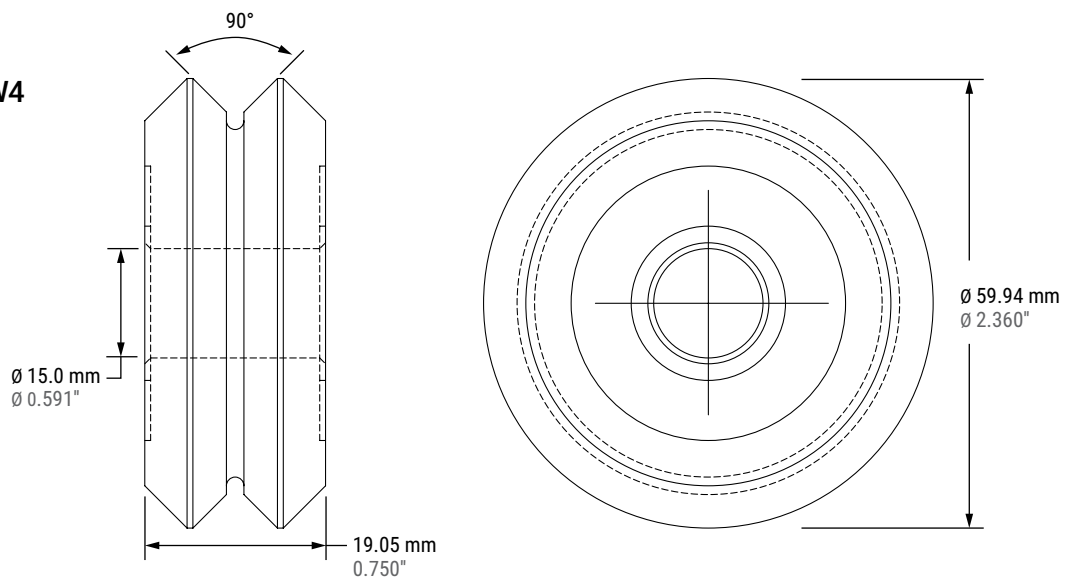

REDI-RAIL

COMMERCIAL
RAIL

HARDENED
CROWN ROLLER

FOLLOWER
ROLLERS

V-GUIDE

HEVI-RAIL

V-Guide Size 1 • 20 mm (3/4")

Radial loads up to 283 lb. (1,260 N) per wheel
Axial loads up to 67 lb. (297 N) per wheel
Wheel weight: .42 oz. (12 g)
Speed rating: 16,000 rpm MAX (13.23 m/s MAX)

V-Guide Wheels

| | |
|--------------|--------------------------|
| VW1 | Shielded Bearing |
| VWS1 | Sealed Bearing |
| VWSS1 | Sealed Stainless Bearing |

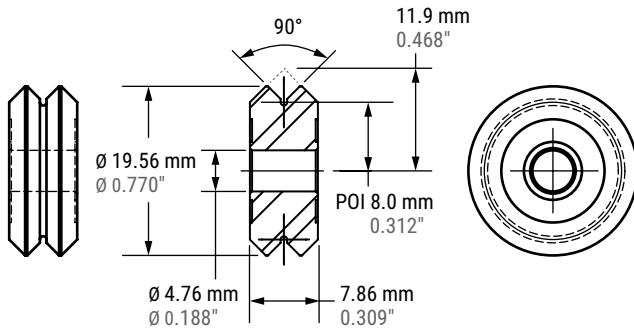

Wheel Bushings

| Inch Series | |
|---------------|-------------------------------------|
| VB1 | Concentric Fixed Bushing |
| VBA1 | Eccentric Adjustable Bushing |
| Metric Series | |
| MVB1 | Concentric Metric Fixed Bushing |
| MVBA1 | Eccentric Metric Adjustable Bushing |

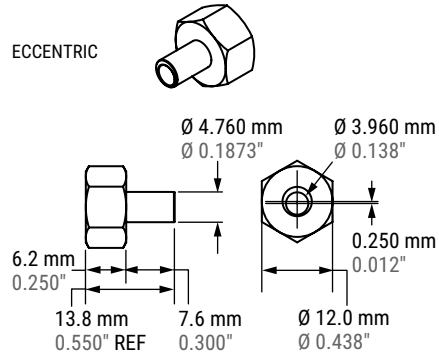
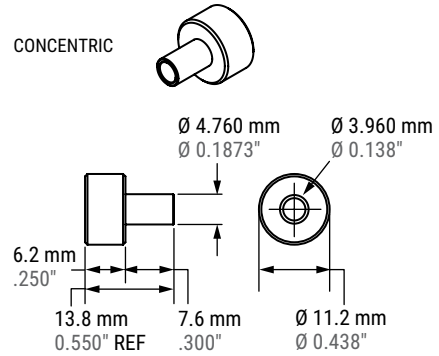

V-Guide Rail

| | Carbon Steel | | Stainless Steel |
|-----------------|--|------------------|--|
| VR1-xxx | undrilled rail, MAX length 216" (5,486.4 mm) | VRS1-xxx | undrilled rail, MAX length 216" (5,486.4 mm) |
| VRD1-xxx | drilled rail | VRSD1-xxx | drilled rail |

Note: Non-heat treated rails available in all sizes, contact factory.
 POI = Point of Intersection

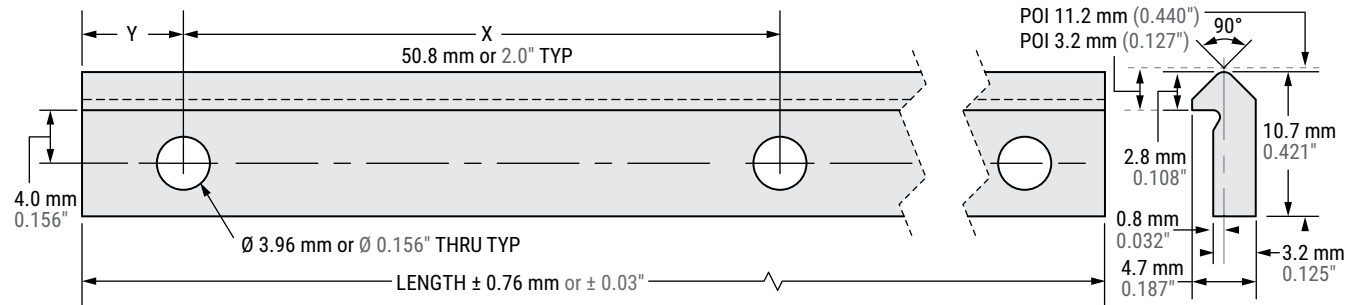

Specify Y dimension (hole to end) at time of order

V-Guide Size 2 · 30 mm (1-1/4")

Radial loads up to 614 lb. (2,730 N) per wheel

Axial loads up to 142 lb. (632 N) per wheel

Wheel weight: 1.3 oz. (38 g)

Speed rating: 9,600 rpm MAX (12.76 m/s MAX)

V-Guide Wheels

| VW2 | Shielded Bearing |
|-------|--------------------------|
| VWS2 | Sealed Bearing |
| VWSS2 | Sealed Stainless Bearing |

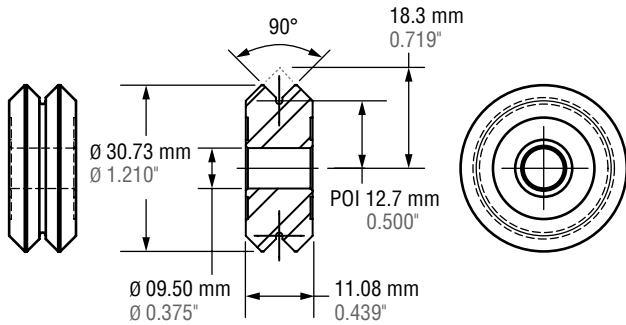

Wheel bushings

| Inch Series | |
|---------------|-------------------------------------|
| VB2 | Concentric Fixed Bushing |
| VBA2 | Eccentric Adjustable Bushing |
| Metric Series | |
| MVB2 | Concentric Metric Fixed Bushing |
| MVBA2 | Eccentric Metric Adjustable Bushing |

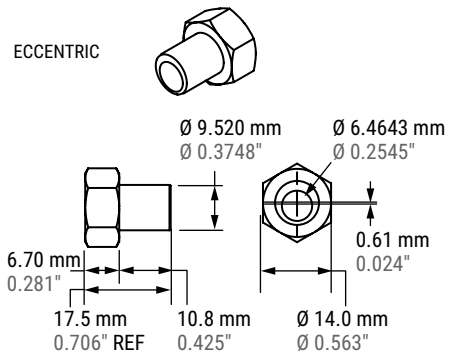
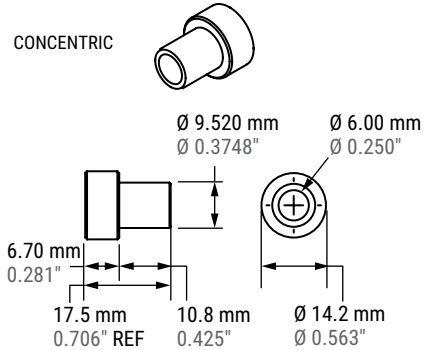

V-Guide Rail

| Carbon Steel | | Stainless Steel | |
|--------------|--|-----------------|--|
| VR2-xxx | undrilled rail, MAX length 216" (5,486.4 mm) | VRS2-xxx | undrilled rail, MAX length 216" (5,486.4 mm) |
| VRD2-xxx | drilled rail | VRSD2-xxx | drilled rail |

Note: Non-heat treated rails available in all sizes, contact factory.

POI = Point of intersection

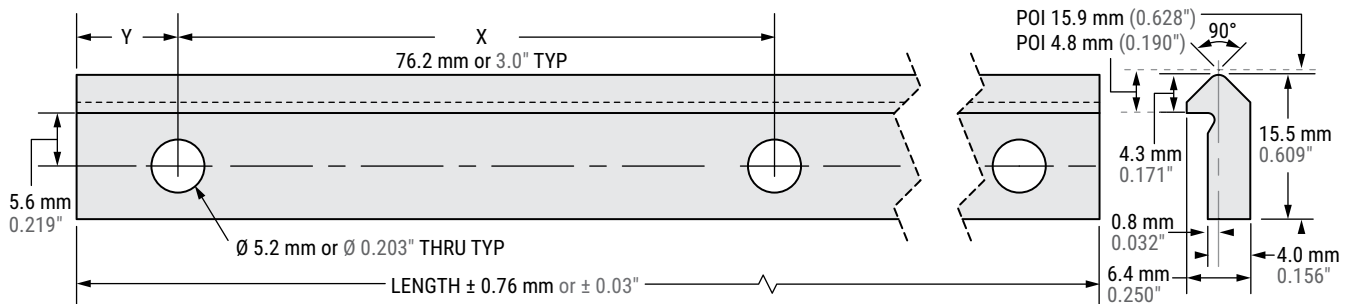

Specify Y dimension (hole to end) at time of order

V-Guide Size 3 · 45 mm (1-3/4")

Radial loads up to 1,386 lb. (6,166 N) per wheel
Axial loads up to 326 lb. (1,448 N) per wheel
Wheel weight: 4.6 oz. (131 g)
Speed rating: 8,000 rpm MAX (16.00 m/s MAX)

V-Guide Wheels

| VW3 | Shielded Bearing |
|-------|--------------------------|
| VWS3 | Sealed Bearing |
| VWSS3 | Sealed Stainless Bearing |

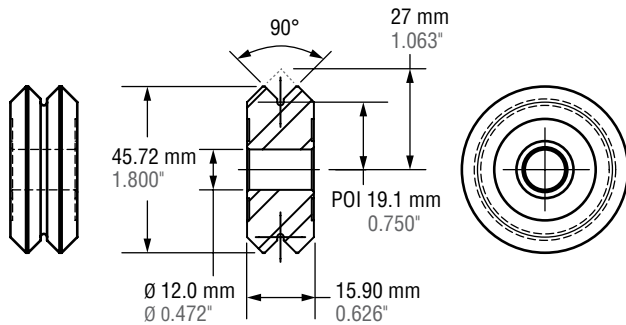

Wheel bushings

| Inch Series | |
|---------------|-------------------------------------|
| VB3 | Concentric Fixed Bushing |
| VBA3 | Eccentric Adjustable Bushing |
| Metric Series | |
| MVB3 | Concentric Metric Fixed Bushing |
| MVBA3 | Eccentric Metric Adjustable Bushing |

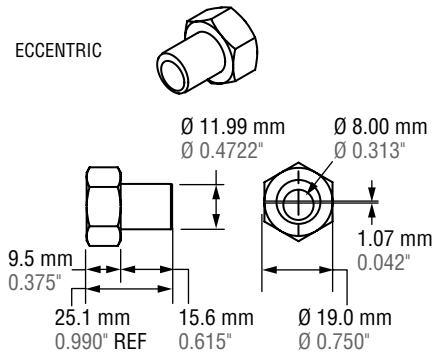
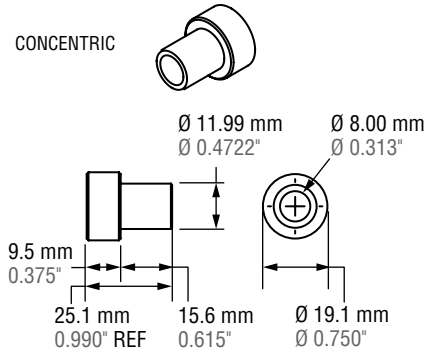

V-Guide Rail

| Carbon Steel | | Stainless Steel | |
|--------------|--|-----------------|--|
| VR3-xxx | undrilled rail, MAX length 216" (5,486.4 mm) | VRS3-xxx | undrilled rail, MAX length 216" (5,486.4 mm) |
| VRD3-xxx | drilled rail | VRSD3-xxx | drilled rail |

Note: Non-heat treated rails available in all sizes, contact factory.
 POI = Point of intersection

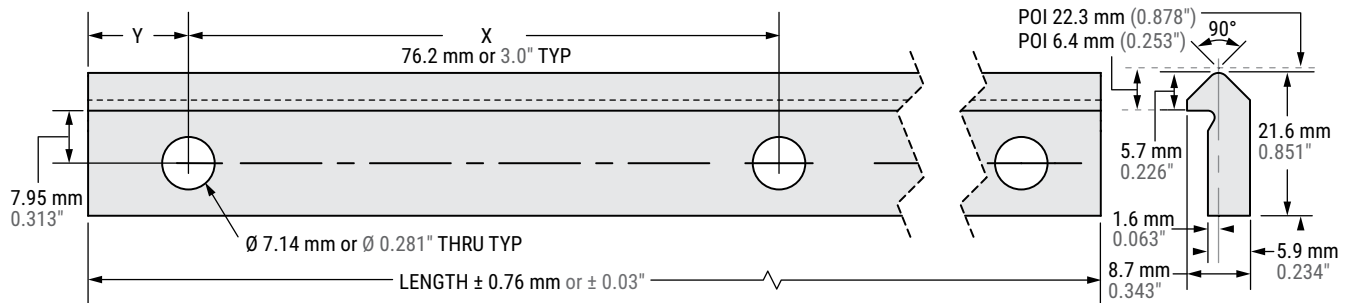

Specify Y dimension (hole to end) at time of order

V-Guide Size 4 · 60 mm (2-1/4")

Radial loads up to 2,246 lb. (9,991 N) per wheel

Axial loads up to 520 lb. (2,313 N) per wheel

Wheel weight: 10 oz. (281 g)

Speed rating: 5,000 rpm MAX (13.30 m/s MAX)

V-Guide Wheels

| VW4 | Shielded Bearing |
|-------|--------------------------|
| VWS4 | Sealed Bearing |
| VWSS4 | Sealed Stainless Bearing |

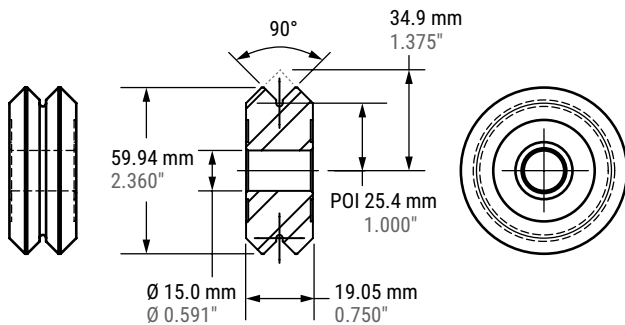

Wheel bushings

| Inch Series | |
|---------------|-------------------------------------|
| VB4 | Concentric Fixed Bushing |
| VBA4 | Eccentric Adjustable Bushing |
| Metric Series | |
| MVB4 | Concentric Metric Fixed Bushing |
| MVBA4 | Eccentric Metric Adjustable Bushing |

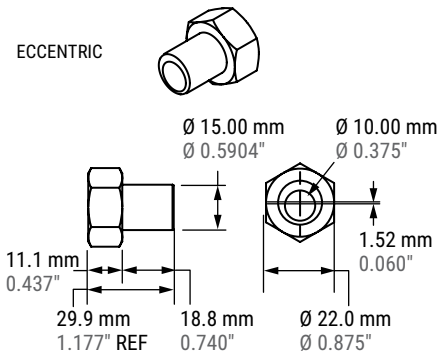
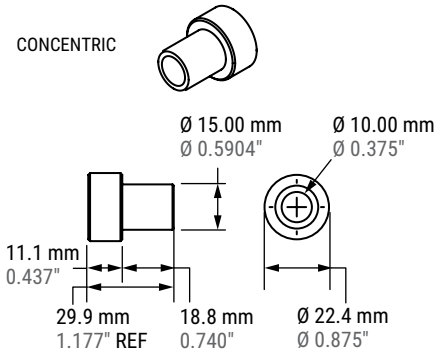

V-Guide Rail

| Carbon Steel | | Stainless Steel | |
|--------------|--|-----------------|--|
| VR4-xxx | undrilled rail, MAX length 216" (5,486.4 mm) | VRS4-xxx | undrilled rail, MAX length 216" (5,486.4 mm) |
| VRD4-xxx | drilled rail | VRSD4-xxx | drilled rail |

Note: Non-heat treated rails available in all sizes, contact factory.

POI = Point of intersection

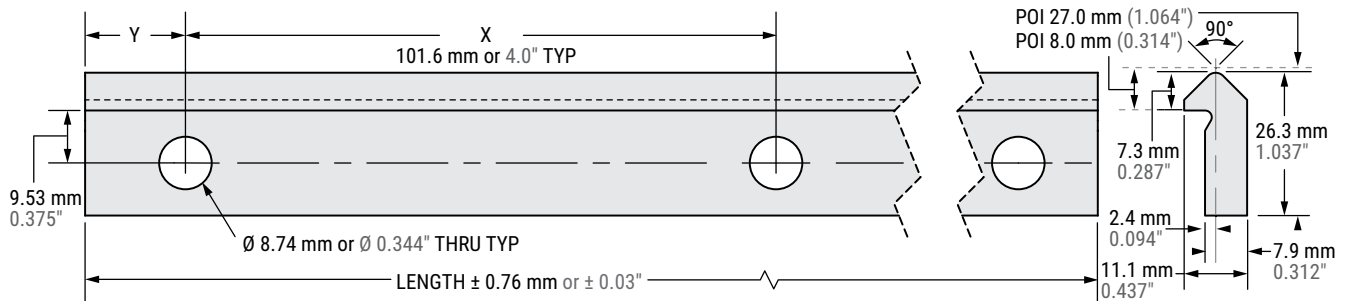

Specify Y dimension (hole to end) at time of order

Technical • Life Calculation

Redi-Rail®

Commercial Rail

Hardened Crown Roller

V-Guide

Hevi-Rail®

Important Notice about Lifetime Calculations

There is no known formula for accurately and reliably calculating the actual lifetime of a linear or rotary bearing system.

The formulas within this section are solely based upon the statistical probability of success. It is important to recognize and distinguish between formulas of absolute certainty and probability.

Even though these formulas are not absolutely certain, they have been generally accepted as the best available method for determining bearing lifetime by the International Organization for Standardization (ISO), as well as its membership bodies; including, but not limited to: American National Standards Institute (ANSI), Deutsches Institut für Normung (DIN) & Japanese Industrial Standards Committee (JISC).

Static & Dynamic Load Ratings

PBC Linear uses the two internationally accepted methods for calculating the Rated Lifetime, Static, and Dynamic Capacities. Per the international standard, all lifetimes are calculated to an L10 life of 100 km (105 meters or ≈ 3.94 million inches). The two standards used are:

- ISO76 Rolling Bearings – Static Load Ratings
- ISO281 Rolling Bearings – Dynamic Load Ratings & Rating Life

Note: Some suppliers may choose to rate their bearings based upon a useful life of less than 100 km or a probability of success less than 90%. This causes their bearings to falsely appear to have a higher static and dynamic load capacity. If a catalog does not specifically note L10 = 100 km, caution should be used when comparing load capacity or life values between suppliers. The most commonly used values are L10 = 50 km and L25 = 50 km. For comparison, at L10 = 100 km, an example bearing has a maximum static load of 1,000 N. That exact same bearing as an L10 = 50 km maximum static load of $\approx 2,300$ N and an L25 = 50 km maximum static load of $\approx 4,600$ N!

In summary, the static load ratings are defined as the maximum applied load (or moment) which will result in the permanent deformation which does not exceed 1/10,000 of the diameter of the rolling element (ball or rod) within the bearing. The basic dynamic load rating, C, is the load of a constant magnitude and direction, which a sufficiently large number of apparently identical bearings can endure for a basic rating life of one million revolutions. It's important to note that both the static and dynamic values are determined through ISO-Approved formulas. These formulas take into account several factors, including the design, internal geometry, material type, material quality, and lubrication type.

Note: Additional factors are provided so that the estimated lifetime (default = 100 km) and/or the probability of success (default = 90%) can be changed from their default value to any desired value.

Operating Lifetime

The Operating Life (or Operating Lifetime) is the actual life achieved by a rolling bearing. The actual lifetime typically varies from the calculated lifetime, sometimes significantly. It is not possible to accurately and reliably determine the actual Operating Life through calculations due to the large variety of operating and installation conditions. The most reliable method to achieve an approximation is by comparing the current application to similar applications. Primary factors which can negatively affect the life and are generally not included in calculations are:

- Contamination within the application
- Inadequate or improper lubrication
- Operational conditions different from calculated values, including unexpected forces and moments
- Insufficient and/or excessive operating clearance between the roller and guideway
- Excessive interference between roller and guideway (typically due to misalignment or excessive preload)
- Temperature out of range
- High shock loads (exceeding static load capacity)
- Vibration (which causes false brinelling resulting from fretting)
- Short stroke reciprocating motion (also causes False Brinelling)
- Damage caused during installation or from improper handling
- Improper mating surface hardness (when not used with a PBC Linear rail)

Technical • Life Calculation

Redi-Rail®

Commercial Rail

Hardened Crown Roller

V-Guide

Hevi-Rail®

Terms, Definitions & Symbols

The following variables are used within the equations listed on the following pages:

- $F_{y\ app}$ = Force applied in the Y direction (radial force), N
- $F_{z\ app}$ = Force applied in the Z direction (axial force), N
- $M_{x\ app}$ = Moment applied about the X axis, N
- $M_{y\ app}$ = Moment applied about the Y axis, N
- $M_{z\ app}$ = Moment applied about the Z axis, N
- F_{MAX} = Maximum allowable force in the Y direction (radial force), N
- $F_{z\ MAX}$ = Maximum allowable force in the Z direction (axial force), N
- $M_{x\ MAX}$ = Maximum allowable moment about the X axis, N • m
- $M_{y\ MAX}$ = Maximum allowable moment about the Y axis, N • m
- $M_{z\ MAX}$ = Maximum allowable moment about the Z axis, N • m
- D_a = Rolling contact diameter, from product tables, mm
- f_h = Shaft (rail)hardness reduction factor
- f_l = Required Lifetime (km) reduction factor
- f_r = Reliability reduction factor
- f_{ss} = Short stroke reduction factor
- L10 = Basic rating life, km (103 m)
- Pr = Equivalent radial (F_y) load, N
- s.f = safety factor

Note: PBC Linear has chosen to depart from the nomenclature standards used by ISO. Instead, PBC Linear uses a convention that is more in line with other PBC Linear products. This ensures that all PBC Linear products use the same naming conventions, making it easier to compare multiple products from different product families. The Y direction (radial force) and Z direction (axial force) are dependant upon the orientation of the wheel bearing.

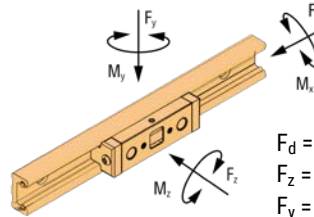

- F_d = Dynamic capacity (LC)
- F_z = Axial capacity
- F_y = Radial capacity
- M_x, M_y, M_z = Moment capacities

Conversions

- newton (N) • 0.2248 = lb.
- (lb) meter • 0.0397 = inch
- newton - meter (N-m) • 8.851 = in.-lb.

Derivation

The lifetime formula within ISO 281 gives the life in millions of revolutions. The conversion from rotary life to linear life is done using the conversion factors listed in the following three equations. This derivation applies to both individual rollers and carriages. Lrev and Ldistance represent the lifetime of the bearing in revolutions and linear distance, respectively.

Note: Attention must be paid to units of measure, especially when considering products from different manufacturers. All of the lifetime formulas within this section yield results in kilometers; however, not all companies follow the same standard. Some companies may express life in meters or 100's of kilometers.

$$L_{Distance} [1 \cdot 10^5 m] = L_{rev} [1,000,000 rev] \cdot \left(3.14 D_a \left[\frac{mm}{rev} \right] \right) \cdot \left(\frac{1 \cdot 10^5 m}{1,000,000,000} \left[\frac{m}{mm} \right] \right) \quad \text{Eq. 1}$$

$$L_{Distance} [1 \cdot 10^5 m] = L_{rev} \cdot (0.0314 D_a) \quad \text{Eq. 2}$$

$$L_{Distance} [km] = 100 \cdot L_{rev} \cdot (0.0314 D_a) = 3.14 \cdot D_a \cdot L_{rev} \quad \text{Eq. 3}$$

TECHNICAL



Link to whitepaper "The Facts About Roller Bearing Life Calculations"

Technical • Life Calculation

Redi-Rail®

Commercial Rail

Hardened Crown Roller

V-Guide

Hevi-Rail®

Individual Rollers – All products except Hevi-Rail Rollers

Most of the individual rollers within this catalog are Radial Ball Bearings. The following formulas should be used for all individual bearings except Hevi-Rail bearings (which are roller bearings). This formula calculates the basic rating life (L10 life), which does not take into account any reduction factors based upon the application.

$$L_{10} [km] = 3.14 \cdot D_a \cdot \left(f_L \cdot f_H \cdot f_{SS} \cdot \frac{F_{y \max}}{P_r} \right)^3 \cdot (f_R) \quad \text{Eq. 4}$$

$$P_r = X \cdot F_{y \text{ app}} + Y \cdot F_{z \text{ app}} \quad \text{Eq. 5}$$



The values for X & Y can be found using the table listed below.

Values of X & Y for Radial Ball Bearing Life Formula

| Product | $\frac{F_{z \text{ app}}}{F_{y \text{ app}}} \leq \epsilon$ | | $\frac{F_{z \text{ app}}}{F_{y \text{ app}}} > \epsilon$ | | ϵ |
|--|---|------|--|------|------------|
| | X | Y | X | Y | |
| Commercial Rail (all sizes) | 1 | 0 | 0.41 | 0.87 | 0.68 |
| Hardened Crown Rollers | 1 | 0 | 0.41 | 0.87 | 0.68 |
| Integral-V (IVT) (Compact Linear Guides) | 1 | 0.78 | 0.63 | 1.24 | 0.80 |
| Integral-V (IVT) (all other sizes & types) | 1 | 0.78 | 0.63 | 1.24 | 0.80 |
| Redi-Rail (all sizes & types) | 1 | 0.78 | 0.63 | 1.24 | 0.80 |
| Steel-Rail (all sizes & types) | 1 | 0.78 | 0.63 | 1.24 | 0.80 |
| V-Rail (all sizes) | 1 | 0.78 | 0.63 | 1.24 | 0.80 |

Redi-Rail®

Commercial Rail

Hardened Crown Roller

V-Guide

Hevi-Rail®

Individual Rollers – Hevi-Rail Rollers

Hevi-Rail bearings are roller bearings, as opposed to radial ball bearings. The formulas are very similar to the formulas shown above, with only some minor changes.

Note: Hevi-Rail rollers are combined bearings. Essentially two bearings combined into one. Life calculations should be performed for both the radial and the axial bearing.

$$L_{L10} [km] = 3.14 \cdot D_a \cdot \left(f_L \cdot f_H \cdot f_{SS} \cdot \frac{F_{y \max}}{F_{y \text{ app}}} \right)^{\frac{10}{3}} \cdot (f_R) \quad \text{Eq. 6}$$

$$L_{a10} [km] = 3.14 \cdot D_a \cdot \left(f_L \cdot f_H \cdot f_{SS} \cdot \frac{F_{z \max}}{F_{z \text{ app}}} \right)^{\frac{10}{3}} \cdot (f_R) \quad \text{Eq. 7}$$

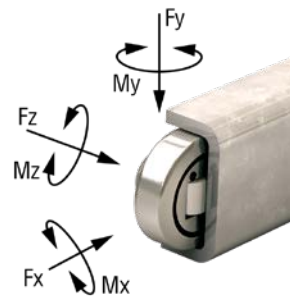

Technical • Life Calculation

| | | | | |
|------------|-----------------|-----------------------|---------|------------|
| Redi-Rail® | Commercial Rail | Hardened Crown Roller | V-Guide | Hevi-Rail® |
|------------|-----------------|-----------------------|---------|------------|

Carriage Assemblies

Formulas for calculating the estimated lifetime for carriage assemblies are fundamentally similar to the calculations for the individual rollers. The most accurate method for determining the life of a carriage assembly is to create a free body diagram for the carriage and determine the axial, radial, and moment load applied to each individual roller. This method is cumbersome and is usually only required in the most severe of circumstances. In most cases, the carriage assembly can be treated as a rigid body and calculations can be completed based upon the load ratings for the entire carriage:



$$L_{10} [km] = 100 \cdot \left(f_L \cdot f_H \cdot f_{SS} \cdot \left(\frac{F_{y app}}{F_{y max}} + \frac{F_{z app}}{F_{z max}} + \frac{M_{x app}}{M_{x max}} + \frac{M_{y app}}{M_{y max}} + \frac{M_{z app}}{M_{z max}} \right) \right)^3 \cdot (f_R) \quad \text{Eq. 8}$$

| | | | | |
|------------|-----------------|-----------------------|---------|------------|
| Redi-Rail® | Commercial Rail | Hardened Crown Roller | V-Guide | Hevi-Rail® |
|------------|-----------------|-----------------------|---------|------------|

Safety Factor

All individual rollers and carriages are subject to use a balancing formula, which ensures an adequate product life. The following formulas should be used for all CRT products:

$$\text{Carriages } \frac{1}{s.f.} \geq \frac{F_{y app}}{F_{y max}} + \frac{F_{z app}}{F_{z max}} + \frac{M_{x app}}{M_{x max}} + \frac{M_{y app}}{M_{y max}} + \frac{M_{z app}}{M_{z max}} \quad \text{Eq. 9}$$

$$\text{Individual Bearings } \frac{1}{s.f.} \geq \frac{F_{y app}}{F_{y max}} + \frac{F_{z app}}{F_{z max}} \quad \text{Eq. 10}$$

Where the safety factor value can be determined using the following table.

Recommended Safety Factor (s.f.)

| Duty | Shock/Vibration | Reverse Frequency | Contamination | S.F. |
|------------|-----------------|-------------------|---------------|-----------|
| Very Light | None | Smooth & Low | None | 1.0 - 1.2 |
| Light | Light | Light | Light | 1.2 - 1.5 |
| Medium | Medium | Medium | Medium | 1.5 - 2.0 |
| Heavy | Heavy | High & Fast | Heavy | 2.0 - 3.5 |

Note: The table above contains suggested safety factors based upon the most commonly encountered adjustment criteria. Additional criteria may require raising the safety factor.

Minimum Load Notice

It is possible to apply too small of a load to a bearing/carriage. In this case, there is a possibility of the outer ring slipping or the roller lifting off the track. This can cause unexpected vibration or skidding, which reduces the life of the bearing. Therefore, the following condition should be met under dynamic load conditions:

There is no minimum load requirement under static conditions.

$$\text{Minimum Dynamic Load } \rightarrow \frac{F_{y max}}{F_{y app}} \leq 50 \quad \text{Eq. 11}$$

Technical • Life Calculation

Redi-Rail®

Commercial Rail

Hardened Crown Roller

V-Guide

Hevi-Rail®

Heavy Load Notice

It is also possible to over load the bearings. Extra-heavy loads can cause unexpected stress concentrations in the bearing or railway, which reduce the actual lifetime below the minimally acceptable level. These stress concentrations typically come from unexpected vibrations within the application or unexpectedly high preload forces caused by misalignment, damage, or thermal expansion. In these cases, a larger safety factor should be used.

$$\text{Use Caution} \rightarrow P_{re} > 0.5 C_r \quad \text{Eq. 12}$$

Note: Although typically applying to linear motion rolling bearings, ISO 14728-1 states that the above equation should be followed. It should be treated as a rule as opposed to a guideline.

If the product under consideration is a carriage (slider) assembly and $P_r > 0.5 \cdot C_r$, then it is recommended to consider the axial, radial and moment load applied to each individual roller to ensure each roller still has an adequate safety factor.

Shaft/Rail Hardness Factor, f_H

It is possible to use a softer rail material in combination with PBC Linear CRT products; however, it is necessary to reduce the static and dynamic load capacities of each product. The reduced load capacity is known as the "Effective Load Capacity", which can be calculated using the formula below. The reduction factor, f_H , can be determined using the table below.

For easy reference, some of the most common materials have been plotted on the on the table below:

$$\text{Dynamic} \rightarrow F_{Y\text{Eff}} = F_Y \cdot f_H \quad \text{Eq. 13}$$

$$\text{Static} \rightarrow F_{OY\text{Eff}} = F_{OY} \cdot f_H \quad \text{Eq. 14}$$

Approximate Comparison of Common International Materials

For easy reference, some of the most common materials have been plotted on the table below:

| # | TYPE | EN NAME | EN # | ASTM/AISI | TYPICAL HARDNESS ² | f_H |
|---|-----------------|-------------|--------|-----------|-------------------------------|----------|
| 1 | Steel | C60 | 1.0601 | 1060 | 60-62 | 1.0 |
| 2 | Steel | 52-3 | 1.0570 | 1024 | 19-22 | 0.1 |
| 3 | Stainless Steel | X46 Cr13 | 1.4034 | 420 | 51-53 | 0.7 |
| 4 | Stainless Steel | X90 CrMoV18 | 1.4112 | 440B | 53-55 | 0.8 |
| 5 | Stainless Steel | X105 CrMo17 | 1.4125 | 440C | 59-61 | 0.95-1.0 |

Note: The values listed in the above table should be considered for reference only. It is critical that individual suppliers are contacted to ensure an accurate hardness rating. Depending upon the supplier, "hardness" can actually be the minimum, maximum, or average value. The wrong interpretation can have unexpected consequences for the application. When given the choice, PBC Linear recommends using the "minimum hardness" when determining the reduction factor as this is the most conservative method.

1. Material Types may not be an exact match. PBC Linear has carefully reviewed the material standards and has determined that if there is not an exact match, the listed materials are the closest approximation. A material specialist should be consulted before translating one material type to another.
2. Different suppliers may have alternate ranges for material hardness, depending upon their heat treating process. Consult manufacturer's specifications for a more exact number/range.

Static & Dynamic Reduction Factors for Lower Raceway Hardness

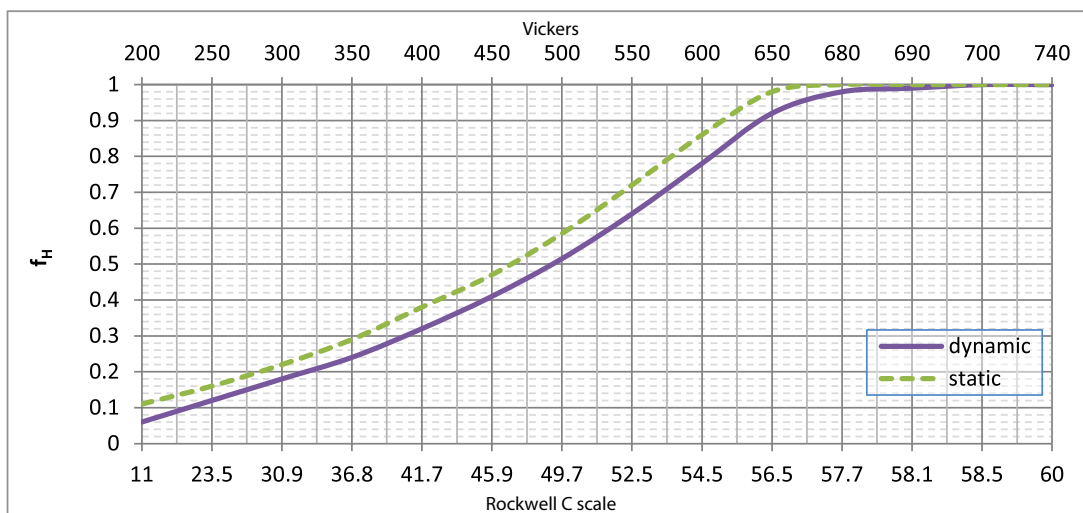

Technical • Life Calculation

Redi-Rail®

Commercial Rail

Hardened Crown Roller

V-Guide

Hevi-Rail®

Required Lifetime (km) Factor, f_L

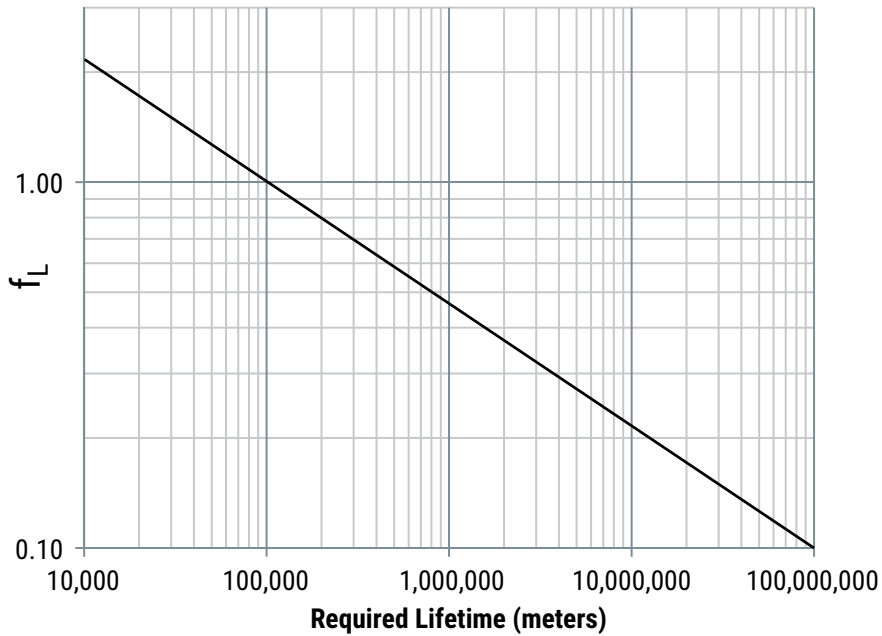

The standard lifetime formulas listed within this catalog describe an L10 life based upon 100 km, in accordance to the applicable ISO standards. Sometimes 100 km is either excessive or shy of the target life of a machine and the required lifetime needs to be adjusted. An appropriate adjustment factor can be found using the chart.

Reliability Factor, f_R

| Reliability | L_n | f_R |
|-------------|------------|-------|
| 50% | L_{50} | 5.04 |
| 60% | L_{40} | 3.83 |
| 70% | L_{30} | 2.77 |
| 80% | L_{20} | 1.82 |
| 90% | L_{10} | 1.0 |
| 95% | L_5 | 0.64 |
| 96% | L_4 | 0.55 |
| 97% | L_3 | 0.47 |
| 98% | L_2 | 0.37 |
| 99% | L_1 | 0.25 |
| 99.2% | $L_{0.8}$ | 0.22 |
| 99.4% | $L_{0.6}$ | 0.19 |
| 99.6% | $L_{0.4}$ | 0.16 |
| 99.8% | $L_{0.2}$ | 0.12 |
| 99.9% | $L_{0.1}$ | 0.093 |
| 99.92% | $L_{0.08}$ | 0.087 |
| 99.94% | $L_{0.06}$ | 0.080 |
| 99.95% | $L_{0.05}$ | 0.077 |

The L10 Life Formulas are a statistical probability formula with a success rate of 90%. Sometimes an L10 life (90% success) is just not good enough and the formulas need to be modified in order to have a higher probability of success. In this case, choose the desired reliability rate and insert the f_R value into the life equation.

Technical • Life Calculation

Redi-Rail®

Commercial Rail

Hardened Crown Roller

V-Guide

Hevi-Rail®

Short Stroke Factor, f_{ss}

In the case that the travel distance is low, a short stroke reduction factor must be included. In general, this factor only applies when the stroke is less than 2x the carriage length. In the case of individual bearings, use two full revolutions of the bearing.

$$\text{Stroke ratio, carriage (slider)} = \frac{\text{stroke [mm]}}{\text{carriage length [mm]}} \quad \text{Eq. 15}$$

$$\text{Stroke ratio, individual bearing} = \frac{\text{stroke [mm]}}{\pi D_p \text{ [mm]}} \quad \text{Eq. 15}$$

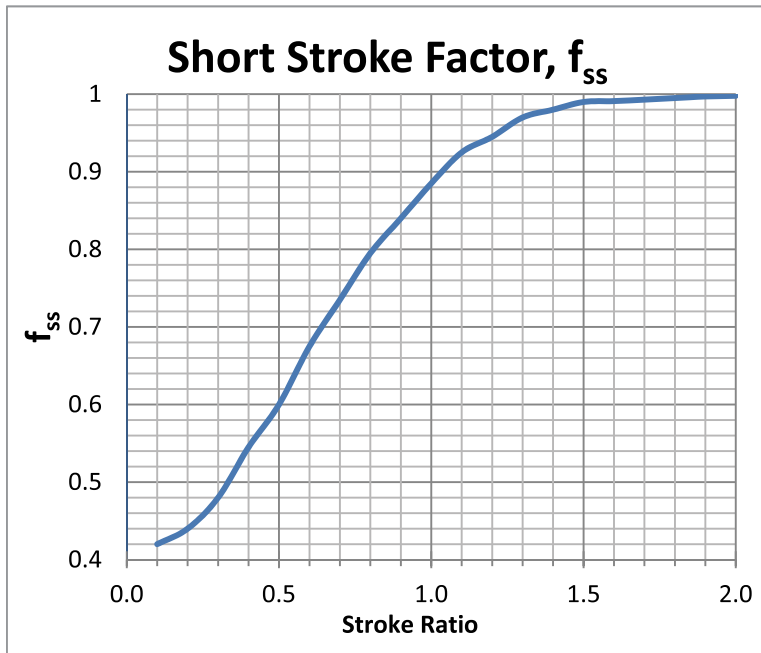

Technical • Installation

Redi-Rail®

Commercial Rail

Hardened Crown Roller

V-Guide

Hevi-Rail®

General Installation

As a general rule, all of the products within the catalog have a higher radial (F_y) than axial (F_z) load capacity. Whenever possible, designers should attempt to orient the bearings so the primary applied load is in the radial direction.

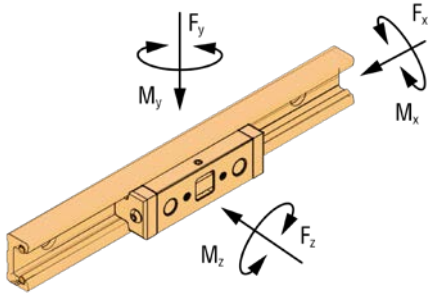

Commercial Rail

Commercial Rail is typically used in applications which require low to moderate accuracy. It is generally not necessary to use any advanced manufacturing or assembly techniques to secure this rail system into place.

Note: If an assembly plan requires Commercial Rail to be installed with dial indicators, calipers, or other sensitive measuring equipment, then likely this product has probably been over-specified for an application. Consider using a more accurate product for these applications, such as the V-Guide System, Redi-Rail, Integral-V (IVT), or Steel Rail.

Hardened Crown Roller Rail

Note: If an assembly plan requires Hardened Crown Roller rails to be installed with dial indicators, calipers, or other sensitive measuring equipment, then it is likely this product has probably been over-specified for an application. Consider using a more accurate product in these applications, such as the V-Guide System, Integral-V (IVT), Redi-Rail, or Flexible Steel Rail.

Redi-Rail

The Redi-Rail product is very versatile and can be used in applications that require low accuracy or moderate-high accuracy. In applications that require low accuracy, no special installation, and alignment procedures are needed. In applications that require moderate to high accuracy, use advanced assembly techniques similar to those used for installing profile rail guideways.

Note: Refer to the PRT (Profile Rail Technology) catalog for more detailed information related to advanced assembly techniques.

Hevi-Rail

Hevi-Rail is typically used in applications that require moderate accuracy. There are two common methods for installing Hevi-Rail: Welding & Clamp Flanges.

Welding

The preferred method of welding Hevi-Rail, Flange Plates, and Hevi-Rail Clamp Flanges is MIG Welding. Please follow the guidelines listed below when MIG welding Hevi-Rail, Flange Plates and Hevi-Rail Clamp Flanges.

1. Use a metal brush or grinder to remove rust or paint from surface to be welded.
2. Bevel joint edges on metals thicker than 3/8" to ensure the weld fully penetrates to the base of the metal. (HVR-2, HVR-3, HVR-4, HVR-5 HVR-6, HVRI-08, HVRI-09, HVRI-10, and HVRI-11).
3. Ensure that grounding clamp is engaged in clean metal.
4. When welding HVR-S, HVR-0, HVR-1, and HVRI-07 sections of Hevi-Rail it is recommended to use 0.03" diameter wire. A preferable grade wire for mild steel is ER70S-3.
5. When welding thick sections of Hevi-Rail, it is recommended to use 0.035"-0.045" ER70S-3 wire. Weld at a higher heat level to obtain a deep penetration. This is recommended for HVR-2, HVR-3, HVR-4, HVR-5 HVR-6, HVRI-08, HVRI-09, HVRI-10, and HVRI-11.
6. A 75% Argon/25% Carbon Dioxide mix is a preferable general purpose shielding gas when welding mild steels like Hevi-Rail.
7. Know your load calculations, when in doubt meet with your structural or mechanical engineer.
8. Destructive testing facilities are recommended for testing weld strength. Periodic destructive testing ensures that the welding equipment and welding practices are yielding safe and strong welds.
9. Never weld a mild steel Hevi-Rail product to a dissimilar metal such as cast iron or stainless steel.

Clamp Flanges

When using bolts to hold a Clamp Flange to Hevi-Rail HVR1, HVR-2, HVR-3, HVR-4, HVR-5, or HVR-6, it is recommend to drill a detent in the top of the rail where the screw seats. Many customers use a drill point smaller than the minor diameter of the tap diameter to put a point in the rail. This is preferred in systems that have vibrations and harmonics in its environment. Some customers use bolts to align and assemble the system, then weld the clamp to the rail.

Technical • Installation

Redi-Rail®

Commercial Rail

Hardened Crown Roller

V-Guide

Hevi-Rail®

V-Guide

V-Rail is typically used in applications that require low to moderate accuracy. The installation accuracy is primarily limited by the accuracy of the mounting surface. It is possible to successfully install V-Rail onto as-extruded bars and plates, or to rolled metal bars and plates. These materials typically do not have very tight dimensional, parallelism, flatness, and straightness tolerances. The loose tolerances add to the overall tolerance stack-up, which reduces the installation accuracy.

A higher grade of accuracy can be achieved by machining the mounting plate, typically through a milling or grinding process. It is possible to achieve an accuracy rating as high as ± 0.025 mm (± 0.001 in.) using machine tool design and assembly techniques. In this case, the mounting surface must be meticulously prepared, and reference edge or dowel pins should be used for alignment purposes.

Note: Integral-V (IVT) products eliminate this alignment process. If an application requires two parallel rails, PBC Linear highly recommends the consideration of the IVT products. Customers have reported significant Total Installed Cost (TIC) savings that have been achieved through the use of IVT products.

General Notes

Handling

Proper handling of PBC Linear products is critical to ensure specified product performance, product life, and to prevent accidental injury. Some products come from the factory with a clearance type preload. These carriages will freely slide if the rail is not kept horizontal. Special attention must be paid when installing the rail overhead or in a vertical orientation.

Special care must also be given to long length units. Single point lifting some products may cause enough bend as to result in permanent, plastic deformation to the railway. Always use suitable lifting equipment that provides enough support to minimize deflection.

Storage

Proper storage is critical in order to maintain an adequate product shelf life. If immediate installation is not possible or practical, it is best to store the product within the package provided by (or designated by) PBC Linear. The product and package should be stored in a horizontal orientation and environmental extremes (high temperature, low temperature, and high humidity) should be avoided. It may be necessary to lubricate steel components during prolonged storage in order to prevent corrosion.

Securing Fasteners

PBC Linear makes no specific recommendation as to whether or not thread-locking fluid (i.e. Loctite®), lock nuts, lock washers, etc., should be used within a given application. Sound engineering fundamentals and company policies should dictate the use of anti-vibration components and technology. Some common reference materials include, but are not limited to:

- Your company's policies and/or engineering specifications
- Marks's Standard Handbook for Mechanical Engineers, published by McGraw-Hill (English)
- Machinery's Handbook, published by Industrial Press (English)
- Roloff/Matek Maschinenelemente, published by Vieweg (German)

Fastener Quantity

It may not be necessary to use a fastener within every supplied fixing hole. This is especially true for applications carrying a light load (high factor of safety). Engineering statics equations can be used to determine the amount of deflection within a rail if not all fixing holes are used. Modern tools, such as FEA, can also be used to speed up this process.

Welding

The recommendations and guidelines listed herein are recommendations only. Always follow your specific company's policies, welding equipment manufacturer's instructions, guidelines established by national standards agencies (i.e. ANSI/DIN) and city/state/federal laws or civil guidelines related to proper welding practices. Improper application or installation of PBC Linear products can result in property damage, death, or serious bodily injury.

Note: Improper installation of carriages with spring-loaded lubricators can permanently damage the lubricator material. Damage caused by improper installation is not covered by PBC Linear warranty.

Initial Lubrication

After installation, follow the initial lubrication instructions located within this catalog or at pbclinear.com. All products are shipped with a preservative material, which should not be considered a true performance lubricant. Lubricant should be added before initial use.

Painting/Powder Coating

Most PBC Linear products can be painted or powder coated after installation to match the aesthetic appearance of the parent structure. It is highly recommended that the bearing's raceway be masked during this process. These coatings will typically not withstand the pressure of a typical operation and will flake off. These flakes will act as bumps causing the rollers to experience unplanned vibration. This can cause an unexpected shortening of the life of the rollers/carriage.

Technical • Lubrication

Redi-Rail®

Commercial Rail

Hardened Crown Roller

V-Guide

Hevi-Rail®

Roller Lubrication

All smaller rollers (in the Redi-Rail, IVT, V-Guide, Commercial Rail, Hardened Crown Roller families, and smaller diameter Hevi-Rail bearings) are lubricated internally for long life.

No additional lubrication is necessary. The rollers are sealed (or shielded) against the operating environment to prevent egress of lubricant, and prevent ingress of contaminants. Some larger rollers (in the Hevi-Rail family) are supplied with a grease access point and can be re-lubricated using a zerk fitting.

Raceway/Guideway Lubrication

To ensure long life, it is necessary to have a thin film of lubrication on the Raceway/Railway at all times. When properly applied, lubrication:

- Reduces wear
- Reduces stress on the contact surfaces
- Reduces friction (and therefore heat buildup)
- Allows for operation at specifications in this catalog (de-rating is required for un-lubricated applications)
- Helps protect the metal surfaces against corrosion (rust and fretting corrosion)

Lubrication Type

Technical, environmental, ecological, and economic factors will determine whether oil or grease should be used in an application. One of the most significant factors in the lubrication selected is the environmental conditions. If extreme conditions are expected, it is highly recommended that a representative from a lubrication company is consulted. This includes heavy contamination when the expected particle size is smaller than 0.1 mm (0.005 in.) as small particles can more easily bypass seals and wipers.

CAUTION! The compatibility of lubricants must always be checked! This check should be



done under both static and dynamic conditions and within the operating environment. Some lubricants may

have unexpected, negative reactions with the plastics, elastomers or non-ferrous metals within the products. It is possible to draw upon previous and practical experience or guidelines from the lubricant manufacturer. When in doubt, consult the lubricant manufacturer.

Initial Lubrication (during installation)

PBC Linear Guides and Raceways are shipped with a preservative lubrication applied to the raceway. During installation, it is necessary to apply additional lubrication. Provided there are no application conflicts, PBC Linear recommends high quality lithium soap grease as the initial lubricant. This grease should be applied to the entire raceway, not just the portion used during normal operation. Oil or grease may be used for re-lubrication.

Note: Coated/Plated rails, Commercial Rail, Hardened Crown Roller, and Hevi-Rail rails are typically shipped without any preservative lubrication. See the Hevi-Rail section for more details: sandblast and lightly oiled option is available for Hevi-Rail.

Periodic Lubrication/Maintenance

The lubrication interval is dependent on many operating and environmental conditions, such as load, stroke, velocity, acceleration, mounting position/orientation, type of lubrication used, temperature, humidity, UV exposure, etc. The actual lubrication interval should be determined by tests conducted under actual application conditions.

While the actual lubrication intervals are application specific and determined only through testing, the following guidelines can typically be used as a starting reference point under normal conditions:

- Re-lubrication every 1,000 km; 50,000 cycles or six months (whichever occurs first).

Technical • Lubrication

Redi-Rail®

Commercial Rail

Hardened Crown Roller

V-Guide

Hevi-Rail®

Oil Filled Polymer Lubricator

Some PBC Linear products offer a high quality polymer lubricator. PBC Linear uses an advanced, oil filled porous polymer, which has been tested to show better performance and longer life than similar wiper/lubricators made of oil or grease filled felt. In some applications, this special lubricator will last the life of the application without additional re-lubrication.

This lubricant within the polymer is NSF Registered for both H1 & H2 applications (Direct and Indirect contact with food). It can also be used for wash down and industrial applications. The lubrication within the polymer contains corrosion inhibitors, anti-oxidants, and extreme pressure (E.P.) additives. The table below shows some specific properties for the lubricant.

Properties for Lubrication in Advanced Oil-Filled Plastic Properties for Lubrication in Advanced Oil-Filled Plastic

| Upper Temp Limit | Lower Temp Limit | Specific Gravity | Viscosity at 40°C cSt | Viscosity at 100°C CST |
|------------------|------------------|------------------|-----------------------|------------------------|
| 99° (210°F) | -40° (-40°F) | 0.86 | 150 | 16.5 |

Used Lubricants

Used lubricants should be disposed of using environmentally-friendly methods. Most lubricant manufacturers have guidelines regarding their allowable storage, use, and disposal. In addition, some countries have regulations regarding storage, use, and disposal of lubricants for occupational safety and/or environmental protection. Furthermore, some companies may have adopted internationally accepted quality and standards policies (i.e. ISO14001), which will further regulate the use of lubricants within an application.

These guidelines and regulations must be followed. Care should be exercised as to not specify a lubricant which is forbidden.

Lubrication Failure

Contamination and lack of lubrication are the two primary causes of (ball based) linear guide failures. Lack of lubrication will cause fretting corrosion, which can cause permanent system damage and eventually lead to system failure. As it applies to this product, fretting corrosion is a form of damage caused as a combination of corrosion and abrasive wear. Fretting corrosion can typically be seen as a reddish discoloration on either mating raceway (track or roller). Fretting corrosion can sometimes be confused with rust. Both are signs that additional lubrication is necessary and the re-lubrication period must be decreased.

Operation in an Un-Lubricated State

While not recommended, it is possible to run most systems without lubrication; however, there will be significant reductions to maximum load, maximum speed, and expected life. The table below shows that a typical un-lubricated system will have a significantly reduced maximum load and a reduced maximum speed when compared to a properly lubricated system.

Typical Reductions for Max Load & Speed for Un-Lubricated Systems

| Product | | Lubricated | Un-Lubricated | Reduction | |
|---------|-----------|------------|---------------|-----------|-----|
| A | Max Load | kg | 100 | 25 | 75% |
| | Max Speed | m/s | 2 | 1.5 | 25% |

In addition to significant reductions in maximum load and speed, un-lubricated system will also experience an extreme reduction in expected life. The table below shows the expected life for both a lubricated and un-lubricated system for two different products with two different applied loads. The approximate reduction in lifetime has also been calculated.

Typical Life Reductions for Un-Lubricated Systems

| Product | | Lubricated | Un-Lubricated | Reduction | |
|---------|----------------|------------|---------------|-----------|-------|
| B | Applied Load 1 | kg | 45.4 | 45.4 | - |
| | Life 1 | m | 5,410,200 | 88,900 | ≈ 98% |
| | Applied Load 2 | kg | 22.7 | 22.7 | - |
| | Life 2 | m | 22,860,000 | 533,400 | ≈ 98% |
| C | Applied Load 3 | kg | 45.4 | 45.4 | - |
| | Life 3 | m | 50,800,000 | 863,600 | ≈ 98% |
| | Applied Load 4 | kg | 90.7 | 90.7 | - |
| | Life 4 | m | 8,382,000 | 152,400 | ≈ 98% |

Note: Actual performance will vary depending upon specific application conditions. PBC Linear has removed the actual product name from the examples listed above as the results may not be repeatable, depending upon specific application conditions. While these values are typical, specific reductions should be determined by tests conducted under actual application conditions.

Technical • General

Redi-Rail®

Commercial Rail

Hardened Crown Roller

V-Guide

Hevi-Rail®

Operating Temperature

The Cam Roller products shown in the catalog have a wide operating temperature limit. All of the products within this catalog can be used within the following range: -20°C to +80°C (-4°F to 176°F). For applications outside of this range, first refer to the specifications for individual products. If a wider range is still needed, please contact our applications engineering group using the contact information below.

The temperature range for these products is limited by the lubricant, engineered polymer wipers, and composite cover materials. In most cases, changing the lubricant or the engineered polymer will extend the operating temperature limit for the product.

Velocity & Acceleration

For maximum velocities, check the product specifications. The maximum velocities will range from 0.76 m/s up to 12 m/s. Higher speeds may be possible, but may not be sustainable. Please contact our applications engineering group for sustained speeds above 12 m/s (33 ft/s).

Unless otherwise noted, the maximum possible acceleration of all CRT products is approximately 5 G's (50 m/s², 160 ft/s²). Higher accelerations are possible, but may not be sustainable. Please contact our applications engineering group for sustained accelerations above 5 G's.

Contact Information

If you need to contact our applications engineering group, please use one of the following methods:

Phone: +1.800.962.8979 (inside USA)

Phone: +1.815.389.5600 (outside USA)

Email: application.engineering@pbclinear.com



Safety guidelines

Product Safety

PBC Linear products are designed and manufactured to the most current level of technology and research. If the bearing (or linear guide) arrangement is designed, handled, installed, and maintained correctly, then they do not give rise to any known or direct hazards. Misapplication, improper handling, improper installation, or improper maintenance may lead to premature product failure, which may have unintended consequences.

Read & Follow Instructions

This publication describes standard products. Since these are used in numerous applications, PBC Linear cannot make a judgment as to whether any malfunctions will cause harm to persons or property. It is always, and fundamentally, the responsibility of the designer and user to ensure that all specifications are observed, and that all necessary safety information is communicated to the end user. This applies in particular to applications in which product failure and/or malfunction may constitute a hazard to human beings.

Symbols

This publication uses several hazard, warning and notification symbols which are defined in accordance to ANSI Z535.6-2006.

Notifications

© PBC Linear 2014. All rights reserved. No part of this publication may be reproduced, stored in a retrieval system, or transmitted in any form or by any means without the prior written permission of PBC Linear.

The data and specifications in this publication have been carefully compiled and are believed to be accurate and correct. However, it is the responsibility of the user to determine and ensure the suitability of PBC Linear products for a specific application. PBC Linear makes no warranty, expressed or implied, regarding the non-infringement, merchantability, or fitness for a particular purpose of the products. No liability is assumed with respect to the use or misuse of the information contained herein. The only obligation on part of PBC Linear will be to repair or replace without charge, any defective components if returned promptly. No liability is assumed beyond such replacement. The appearance, specifications, and other information are subject to change without notice to improve reliability, function, performance, etc.

PBC Linear shall not be responsible for special, indirect or consequential damages, loss of profits or commercial loss in any way connected with the products, whether such claim is based on contract, warranty, negligence, or strict liability.

Trademarks & Copyrights: Product and System names are service marks, trademarks, or registered trademarks of their respective companies. Their use within this publication is without intent to infringe. This notice is accurate as of the date of publication. Visit pbclinear.com for the most current version of this notice, as well as for the most current product information.



A Pacific Bearing Company

Engineering Your Linear Motion Solutions



Global Footprint



📍 PBC Linear Worldwide Headquarters

6402 E. Rockton Road, Roscoe, Illinois 61073 USA

Tel: +1.815.389.5600 • Toll-Free: +1.800.962.8979

Fax: +1.815.389.5790

sales@pbclinear.com • pbclinear.com

📍 PBC Linear Europe GmbH European Headquarters

Bonner Straße 363, 40589 Duesseldorf, Germany

Tel: +49 211 545590 20 • Fax: +49 211 545590 39

info@pbclinear.eu • pbclinear.eu

📍 PBC-MOONS China Headquarters

168 Mingjia Road, Minhang District, Shanghai 201107, P.R. China

Tel: +86 21 52634688 • Fax: +86 21 52634098

info@moons.com.cn • www.moons.com.cn

Range of Offerings



Components

Mechatronics

Request a FREE Product Sample

pbclinear.com/Contact-Us/Sample-Request



All information within this catalog is correct at the time of printing. However, in some instances adjustments need to be made, and this may cause specific information to become outdated. For the most current version, please reference our online catalog through the resources menu at pbclinear.com.

Distributed by

PBC Linear has a global network of distributors with thousands of locations worldwide.

Visit pbclinear.com to find a distributor near you.

©2014 PBC Linear®, A Pacific Bearing Company • "PBC Linear" and "PBC Lineartechnik GmbH" are subsidiaries of Pacific Bearing Company ("PBC"). Specifications are subject to change without notice. It is the responsibility of the user to determine and ensure the suitability of PBC's products for a specific application. PBC's only obligation will be to repair or replace, without charge, any defective components if returned promptly. No liability is assumed beyond such replacement. Other corporate and product names, images, text and logos may be trademarks or copyrights of other companies and are used only for explanation and to the owners benefit; without intent to infringe. This document may not be reproduced, in part or whole, without the prior written authorization of PBC. Consult pbclinear.com for the latest technical updates.

LITCRT-005 v28 (08-2024)